

Balancing Risk versus Benefit in the Selection of Equipment for Portland's Bull Run UV Disinfection Facility

Bryan Townsend¹ Chad Talbot², Harold Wright³, David Peters² and Timothy Phelan⁴

¹Black & Veatch, 8520 Cliff Cameron Drive, Suite 210, Charlotte, NC 28269

²Portland Water Bureau, 1120 SW 5th Avenue, Portland, OR 97204

³Carollo Engineers, 12592 West Explorer Drive, Suite 200, Boise, ID 83713

⁴Black & Veatch, 612 Isabella Crescent, Trail, BC, Canada V1R 1B2

ABSTRACT

In order to comply with the Long Term 2 Enhanced Surface Water Treatment Rule, the Portland Water Bureau has begun the design of a 212 mgd UV disinfection facility to achieve the 2-log Cryptosporidium inactivation requirement for unfiltered surface waters. Since the Bull Run facility does not have a clear well prior to entry in the distribution system, a major focal point of the evaluation was the issue of lamp breakage and potential mercury release. Of the three designs proposed by UV manufacturers, not a single reactor was completely validated. As a result, the level of risk associated with the validation status of each design was also a key aspect of the evaluation. Careful assessment of the benefits of each design and the associated risks was paramount in order to identify the best suited equipment for the Bull Run UV disinfection facility, which was not only attractive from a financial perspective, but also would safely and reliably provide the required disinfection to protect the public health.

Key words: Design, disinfection, mercury, ultraviolet, UV, validation

INTRODUCTION

The primary source of water for the City of Portland (City) is the 102 square miles of the Bull Run watershed, located approximately 22 miles east of Portland in the Mount Hood National Forest. The federally owned and protected watershed is managed by the U.S. Forest Service in cooperation with the City. The City has two dam structures within the watershed, Dam 1 and Dam 2, which create two water reservoirs with a combined storage capacity of 16.5 billion gallons. This water is transported from the lower dam (Dam 2) to the Portland metropolitan area via three large-diameter pipelines: Conduits 2, 3, and 4.

At the present time, the excellent quality and protection of the Bull Run water source have allowed the Portland Water Bureau (PWB) to meet the filtration avoidance criteria of the Surface Water Treatment Rule, as determined by the Oregon Department of Human Services, Public Health Division, Drinking Water Program. Treatment of the Bull Run water consists of coarse screening, followed by the addition of chlorine for disinfection as the water enters the three conduits. The amount of chlorine added is carefully controlled by operations staff, so that a 4-log inactivation of viruses and a 3-log inactivation of Giardia criteria are met. Ten miles downstream of the entrance to the conduits ammonia is added to the water to form chloramines, which allows a disinfectant residual to be maintained throughout the distribution system.

In 2006, the United States Environmental Protection Agency finalized the Long Term 2 Enhanced Surface Water

Treatment Rule (LT2), which formalized the treatment requirements for *Cryptosporidium* for public water systems using surface water or ground water that is under the direct influence of surface water. Under this rule, the EPA requires the City to provide additional treatment to the Bull Run source water.

Portland has a unique, protected water system with a demonstrably low concentration of *Cryptosporidium* in the water. Water monitoring results have shown zero *Cryptosporidium* oocysts in more than 8 years of sampling and testing. PWB is simultaneously seeking alternative and conventional compliance solutions, in its efforts to meet the requirements of the LT2 rule. For alternative compliance, PWB is seeking a variance to the LT2 rule. The variance request will attempt to show that, because of the nature of the raw Bull Run water source, treatment for *Cryptosporidium* is not necessary for public health protection. If the variance request is denied, then the PWB will construct UV disinfection facilities.

For its conventional compliance solution, PWB has chosen ultraviolet (UV) light disinfection treatment. Since there is not sufficient time to design and construct a UV facility between when a variance decision is expected (late 2011) and the LT2 treatment deadline (April 1, 2014), the Portland City Council has directed the PWB to design the UV system in parallel with the development of the variance application. Specifically, the UV system is being designed to provide *Cryptosporidium* inactivation as required under the LT2 rule.

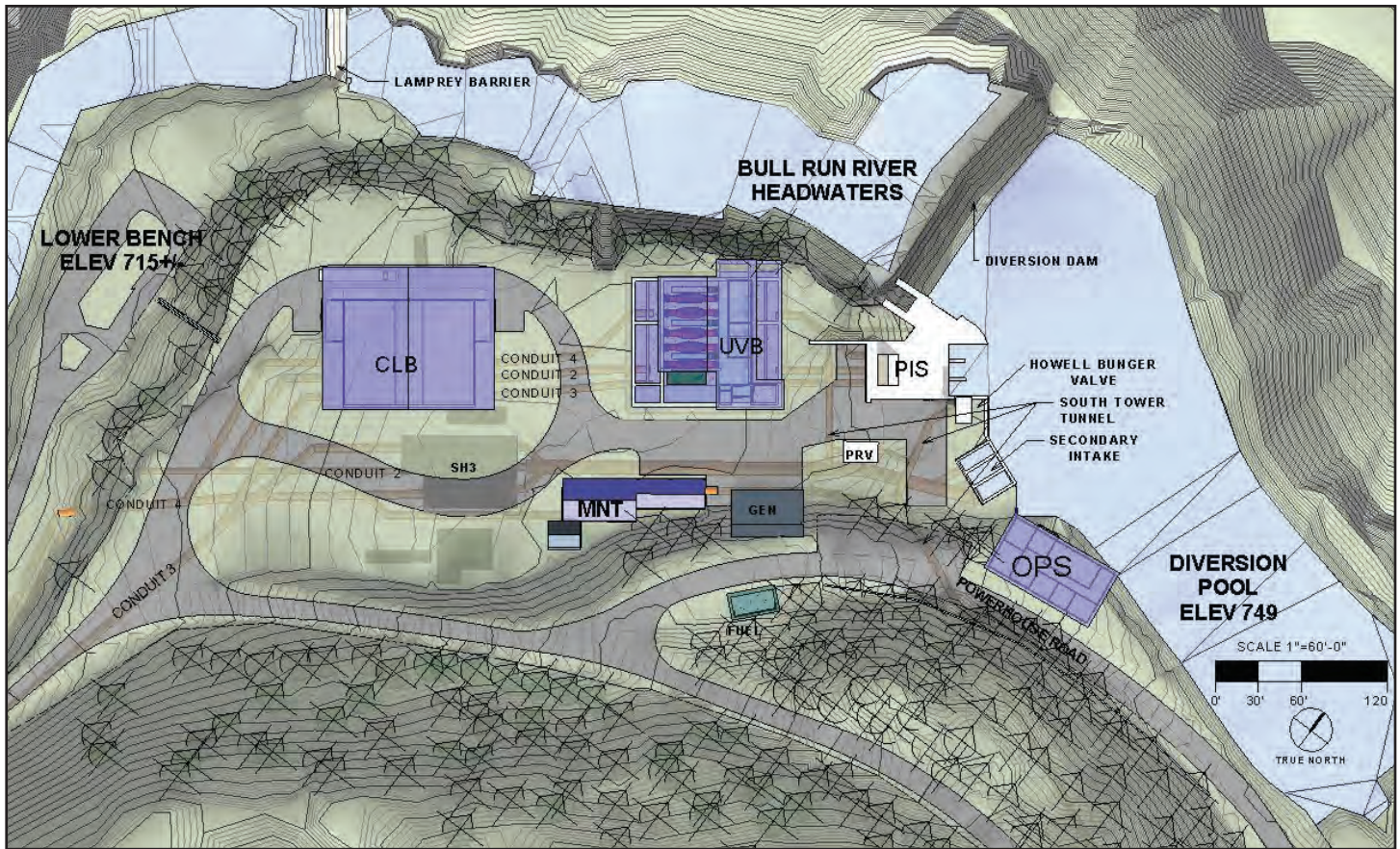

Figure 1: Bull Run Treatment Facilities at Headworks

The design of the UV disinfection system necessitated adjustment of other elements of the existing treatment facilities. Enhancements associated with the UV (UVB) treatment facility include the addition of an operations building (OPS), improvements to chlorination facilities (CLB) and creation of maintenance facilities (MNT). **Figure 1** shows the layout of the Bull Run Treatment facilities.

UV System Design Criteria

PWB decided to pre-select the UV disinfection system prior to the onset of the UV facility design so the location, building and associated facilities (controls, communications and backup power) could be based on the specific requirements of the selected reactor. Black & Veatch and Carollo Engineers supported the pre-selection activities, providing technical assistance for the development of the procurement documents, review of UV design proposals and selection of the UV equipment.

The Bull Run Treatment Facility does not include a clear well, thus special attention was paid to the issue of potential lamp breaks in operating UV reactors and subsequent mercury release into the distribution system. PWB requested UV system designs were to be based on two general design approaches. The first approach was the common header design, where influent to the UV facility was combined into a common source from the three conduits prior to distribution to the UV reactors, and then redistributed to the conduits following disinfection. An additional UV reactor would be provided for redundancy, so the UV facility could

operate at 100 percent capacity with one reactor out of service. In the event of a lamp break within a single reactor, the mercury released into the water could contaminate the effluent entering each conduit, potentially resulting in the need to shut down and isolate all conduits in the event that the mercury concentration surpassed the maximum contaminant level (MCL) of 0.002 mg/L. An example layout of the common header design approach is presented in **Figure 2**.

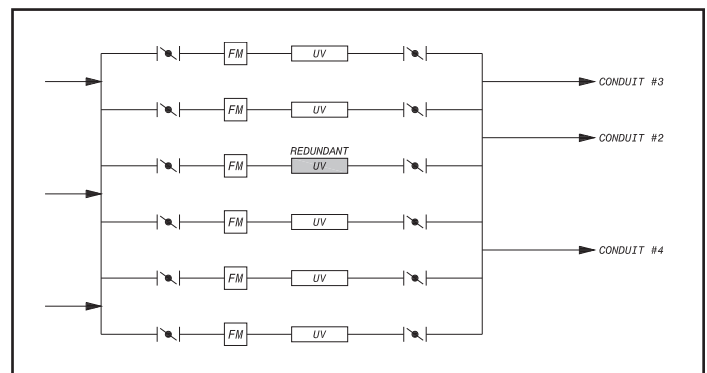

Figure 2: Common Header Design Approach

In order to avoid a catastrophic event requiring the shutting down of the entire UV facility, the second design approach incorporated a separate conduit design, where the flow from each conduit was disinfected by its own set of UV reactors. This approach resulted in the design of three smaller, separate UV systems, with a single redundant

reactor shared between the three conduits. This design allowed for the shut down and isolation of a single conduit should a UV reactor have a lamp break event, thus avoiding contamination of the other conduits. An example layout of the separate conduit design approach is presented in **Figure 3**.

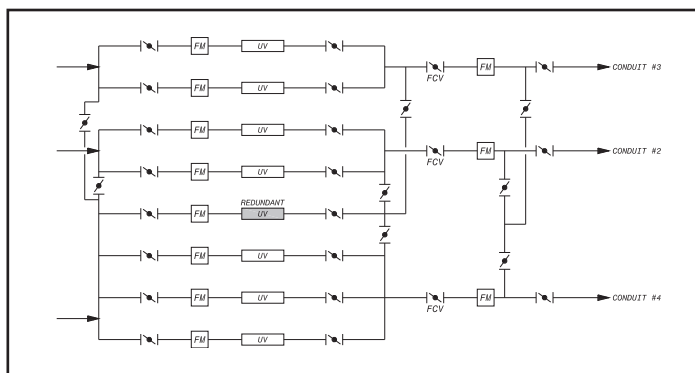

Figure 3: Individual Conduit Design Approach

In an effort to avoid design limitations and allow manufacturers added flexibility to optimize the reactor design for the Bull Run facility, UV manufacturers were allowed to propose designs based on either pre-validated or non-validated reactors. Reactors would need to be validated and approved to support the UV system sizing

prior to shipment to the Bull Run facility. For both the combined header and individual conduit design options, UV systems were required to be sized to provide a 3-log inactivation of *Cryptosporidium*, with expansion capacity to provide 3.5-log inactivation in the future. UV system sizing requirements included a 20% safety factor applied to the required dose to act as an operating buffer for UV system, resulting in a target validated UV dose requirement of 14.4 mJ/cm², expandable to 18.0 mJ/cm².

For the combined header approach, the UV system was required to provide the target UV dose at all of the monthly flow and UVT conditions presented in **Table 1**.

Table 1: Flows and UVTs for Common Header Design Approach

Month	Flow Rate (mgd)	UVT (%)	Month	Flow Rate (mgd)	UVT (%)
January	96	83	July	186	85
February	99	83	August	170	88
March	94	84	September	146	85
April	102	84	October	119	80
May	161	85	November	107	79
June	170	86	December	102	79

A UVT of 82 percent was selected as the design requirement for the individual conduit approach at the flow rates presented in **Table 2**.

Dedicated to providing accurate & innovative analytical services.

Providing UV Reactor Validation
Microbial Support Worldwide

Advancing quality standards beyond industry expectations.

gaplab.com



Table 2: Flows and UVTs for Common Header Design Approach

Conduit	Flow Rate	UVT
	(mgd)	(%)
Conduit 2	52	82
Conduit 3	67	82
Conduit 4	94	82

In addition to the capital cost for the UV equipment, UV manufacturers were required to provide power consumption guarantees for their designs, which will be confirmed during the performance testing of the selected UV system prior to final approval. The power guarantees provided by the manufacturers were based on providing the design target dose of 14.4 mJ/cm² to achieve a 3-log inactivation of *Cryptosporidium* (plus 20 percent DVAL operating safety factor) at the average quarterly flow rates and UVTs for both the common header and individual conduit design approaches.

PWB identified a list of criteria that would be used to evaluate each UV design proposal in addition to the capital and O&M present worth costs. UV manufacturers were required to fill out a questionnaire that addressed UV manufacturer experience and qualifications; Diversity; UV reactor validation and design; Service and support; Disinfection capacity and turndown; Reactor expansion capacity; UV system operation, interaction and flexibility; Off-specification avoidance and monitoring; Mercury release concerns and lamp break monitoring; Hydraulic considerations; and Reactor maintenance and cleaning system operation

UV Equipment Proposal Evaluation

Information provided by UV manufacturers in the questionnaires, along with capital and O&M present worth costs were used to evaluate and score each UV system proposal by the PWB evaluation committee in June of 2010. A total of three UV manufacturers provided proposals for the Bull Run UV facility. Manufacturer C provided two designs for each approach, including a base design requiring off-line chemical cleaning and an alternate design with an on-line mechanical/chemical cleaning system. The proposed UV system design details are presented in **Table 3** for the combined header design approach and in **Table 4** for the individual conduit design approach.

In addition to the capital and O&M present worth costs, two evaluation criteria had a critical impact on the UV selection process. Of the three manufactures that provided proposals, not a single reactor was completely validated. As a result, special attention was required in order to assess the level of risk associated with the validation status for each individual UV system design. The potential impact of lamp break events was also a critical criterion, as the result of this evaluation would determine if the common header or individual conduit design approach was more appropriate for each UV reactor in order to better address the concerns associated with mercury release.

Table 3: Proposed UV System Designs for Combined Header Design Approach

	Manufacturer A	Manufacturer B	Manufacturer C
	Lamp Technology	MP	LPHO
# of Reactors (w/ redundant)	5	5	6
Flange Diameter (in)	48	48	48
# of Lamps per Reactor	9	132	40
Total #. of Lamp/Sleeves	45	660	240
Total # of Ballasts	45	330	120
Total # of Sensors	45	55	30
Cleaning System Type	OMC ¹	OCC ³	OCC ¹ or OMCC ²
Validation Status	incomplete	not validated	not validated

¹OMC: On-line mechanical cleaning; ²OMCC: On-line mechanical/chemical cleaning; ³OCC: Off-line chemical cleaning

UV Reactor Validation Status

Manufacturers A, B and C proposed UV system designs based on UV reactors that were varied in validation status, ranging between preliminary performance models based on incomplete validation results to non-validated reactors employing new lamp and ballast technologies. Although a final, complete validation report was not available for any of the UV manufacturers, the uncertainty associated with the sizing of these systems was unique to each design.

Manufacturer A provided a draft validation report, however, during the evaluation it was determined that the upper validated flow rate limit was slightly below the required flow rate per train for a design having four duty reactors. Additional validation work on the proposed UV system had already been planned by the manufacturer with additional test points easily added to extend the validation envelope and address this shortcoming for the Bull Run design. The risk associated with the slight extrapolation of the current data set to predict the performance of the Bull Run UV facility was considered to be minimal especially since the existing models were based on a robust set of biosimetry results.

The UV reactor proposed by Manufacturer B had not been validated. The UV reactors proposed for the Bull Run UV Facility ranged between 11 to 14 banks of lamps per reactor, with the design proposed for Bull Run based on the validated models of a 7-bank reactor. This reactor along with several similar reactors had been validated by the UV manufacturer in the past, all using the same lamp, ballast, sensor and sleeve technologies and having the same wetted dimensions as the proposed design with respect to lamp and sensor placement in the reactor body. Evaluation of prior validation data supported that extrapolation of the sizing equations developed from the 7-bank reactor validation would likely provide a reliable prediction of disinfection performance for the Bull Run designs with low risk.

Manufacturer C also proposed UV reactor designs that were based on a non-validated UV reactor. However, the risk associated with these designs was identified to be

substantially greater than that associated with Manufacturer B. While a similar reactor geometry had been previously validated, the designs proposed for Bull Run included reactors with brand new lamp and ballast technologies, that had never before undergone validation. In addition, the lamps and ballasts used in the proposed reactor had no track record, as they were not installed in any other operating UV facilities. As a result, the reliability of these components could not be assessed.

An important aspect of evaluating the risk associated with designs based on non-validated UV reactors is to determine what options are available should the performance obtained during validation fall short of the predicted performance used for UV reactor sizing. The first issue that must be determined is the margin of safety that is available in the current design, as is presented in **Table 5** for both design approaches. Second, options need to be identified as to how the proposed UV system design can be modified should the margin of safety not be able to adequately compensate for the reduction in the validated disinfection capacity.

Table 5: Design Margin of Safety for 3-Log Inactivation of *Cryptosporidium*

Design Approach	Manufacturer A	Manufacturer B	Manufacturer C
Common Header	1.65	1.09	1.11
Individual Conduit	1.05 – 1.63	1.03 -1.04	0.99 -1.06

The design margin of safety in **Table 5** is a measurement of the excess treatment capacity that is available in a UV system design with a value of 1.00 representing a UV system with no additional treatment capacity, and a value greater than 1.00 demonstrating excess treatment capacity. The margin of safety for the design proposed by Manufacturer B was 1.09 for the combined header design approach, but was lower for the individual conduit design approach, ranging between 1.03 and 1.04. If the design margin of safety is not adequate to compensate for any reduction in the validated disinfection capacity, additional rows can be added to each reactor. From a design perspective, this approach is highly favorable since it will have a minimum impact on the UV facility design, as additional treatment trains will not be required.

The design margin of safety of 1.11 for Manufacturer C was slightly higher for the combined header design approach as compared to Manufacturer B. However, the margin for the individual conduit design approach was slim, ranging between 0.99 and 1.06, supporting that there is little, if any, room for error in the sizing of the UV reactors. If the design margin of safety is not adequate to compensate for any reduction in validated disinfection capacity, the ability to expand the existing UV reactors is restricted, as these reactors are limited to a maximum of 40 lamps per reactor. Therefore, if added disinfection capacity is required, it may need to be obtained through the installation of an additional treatment train.

**GROUNDBREAKING TECHNOLOGIES...
TESTED AND TRUE.**

carollo
Engineers...Working Wonders With Water®

Pilot Testing of the Latest Microwave UV Technology for a North Texas Municipality

A leader in innovative technologies, the Carollo Research Group performs independent third-party analysis of the latest UV systems for reuse, wastewater, and drinking water disinfection, including ultra-high intensity low-pressure lamps, medium-pressure reactors, sensor-based systems, and microwave UV systems. Along with detailed testing, Carollo provides our clients with groundbreaking solutions for maximum performance and cost savings. Contact us today, and together we can begin "Working Wonders With Water®"... with you.

1.800.523.5826 | carollo.com

Lamp Break and Mercury Release

Although lamp breaks in operating UV reactors are rare events, the lack of a clear well at the Bull Run treatment facility required an in depth evaluation of the potential mercury concentrations that could exist in the conduits following a lamp break. Amalgam LPHO lamps, such as those used by Manufacturers B and C, typically contain between 40 and 150 mg of mercury, usually present as a solid indium-mercury amalgam attached to the inside surface of the lamp envelope. In contrast, MP lamps, like those used by Manufacturer A, typically contain between 200 and 2,000 mg of mercury. When a lamp breaks, mercury in the liquid and amalgam phase is expected to settle to the bottom of the reactor because mercury has a high density (13.534 g/mL). However, vapor phase mercury is expected to disperse into the water passing through the reactor.

The amount of mercury in the vapor phase depends on the lamp type. With an operating MP lamp, most if not all of the mercury should be in the vapor phase because the lamp operates at a high temperature (600 to 800 °C). On the other hand, with an operating amalgam LPHO lamp, only a small fraction of the total mercury will be in the vapor phase because the lamps operate at a lower temperatures and vapor pressures.

In the event of a lamp break, the mass of mercury released by a UV lamp in the gas phase can be estimated using the Ideal Gas Law (WRF 2010). The transport of mercury downstream from the breakage event was modeled using

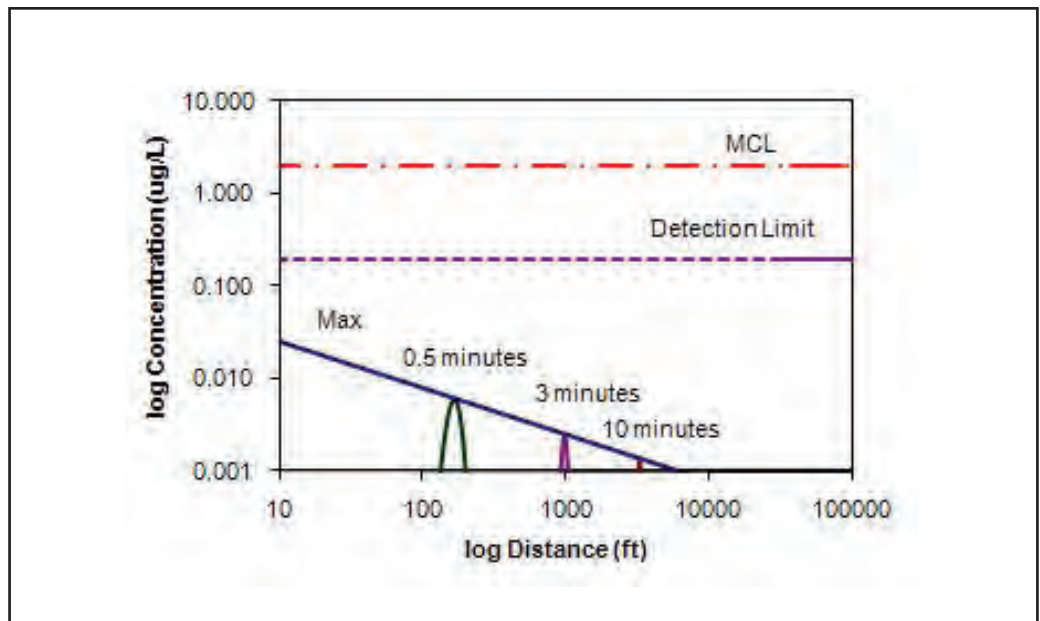

Figure 5: Predicted Mercury Dispersion following a Single LPHO Lamp Break – Manufacturer B and C

the one-dimensional Advective Dispersive Equation (ADE). With the ADE, it is assumed that the released mercury is quickly dissipated uniformly across the pipe cross section, and the dispersion caused by bends, valves, Tees, and other pipe fittings is not accounted for. However, those affects are expected to be small with long lengths of straight pipe associated with the Bull Run conduits. Predictions of mercury concentrations as a function of time at various locations downstream of the reactor following the breakage of a single lamp are presented in **Figures 4 and 5**. The

model assumed a flow of 94 mgd enters a single 60-inch conduit. The model predicts a bell-shaped mercury concentration profile as a function of time. The peak of the concentration profile decreases as the mercury is dispersed during its travel down the conduit.

A single LPHO lamp break in the UV reactors proposed by Manufacturers B and C results in a maximum mercury concentration directly downstream of the reactor that is well below the detection limit of EPA methods 245.1 and 245.2 (0.2 $\mu\text{g/L}$), and greater than two orders of magnitude below the mercury MCL (2 $\mu\text{g/L}$). After traveling

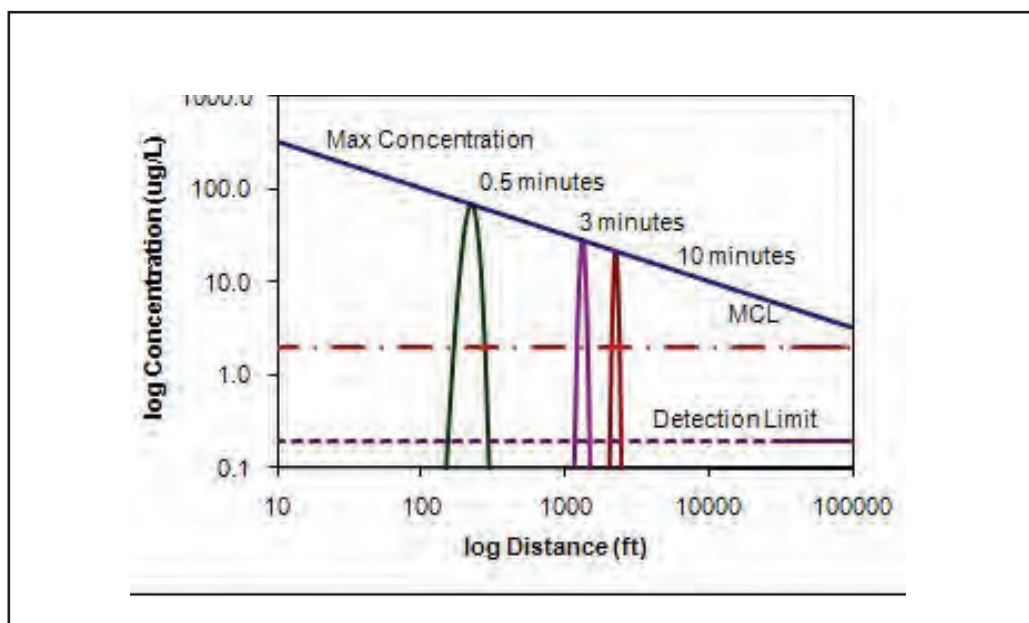

Figure 4: Predicted Mercury Dispersion following a Single MP Lamp Break – Manufacturer A

approximately 7,000 feet downstream of the reactors, the increased dispersion results in a mercury concentration that is less than expected background concentration of 0.001 $\mu\text{g}/\text{L}$ for the Bull Run supply. These results support that multiple LPHO lamp breaks could occur simultaneously with concentrations remaining well below the MCL and detection limit.

A single MP lamp break in the UV reactor proposed by Manufacturer A results in a dramatically higher concentration directly downstream of the reactor immediately following the break, which is two orders of magnitude greater than the mercury MCL. Furthermore, after traveling 100,000 feet (approximately 19 miles), the mercury concentration would still be expected to be in excess of the MCL.

Cost Evaluation

The capital costs developed for each UV system design consisted of UV equipment costs provided by each manufacturer and estimates of building costs; valves, piping and flow meters; equipment installation; and electrical requirements. Annual operation and maintenance (O&M) cost calculations for each UV system design incorporated the power guarantees provided by each manufacturer for the average quarterly flow rates and UVTs, along with the guaranteed lifetimes and replacement costs for reactor consumables, calibration services and typical maintenance requirements. Calculations assumed continuous UV system operation for 8,760 hours per year and an energy cost of \$0.07 per kilowatt-hour. O&M present worth was calculated based on a 20-year lifetime and interest rate of 3 percent. Present worth O&M costs were added to the capital cost for each design to determine the total present worth cost for each UV facility, presented in **Figure 6**.

CONCLUSIONS

The high mercury concentrations and predicted dispersion characteristics of the UV reactor designs proposed by Manufacturer A support that the individual conduit design approach is more appropriate for reactors with MP lamps. In the event of a lamp break, an individual conduit can be isolated and treated to remove the mercury contamination without impacting the operation of the other conduits. The mercury dispersion characteristics associated with the designs from Manufacturers B and C support that a common header design approach is a viable option for reactors with LPHO lamps due to the low levels of mercury that would be associated with single and multiple lamp breaks. Consequently, the total present worth cost for the UV facility for Manufacturer A based on the individual conduit design approach is \$1.3 million (15 percent) higher than the most expensive LPHO design option based on the combined header design approach (Manufacturer B). Although the UV system selection included scoring of non-financial evaluation criteria, the elevated costs associated with the individual conduit design approach were too great for Manufacturer A to overcome with scoring from other categories.

A maximum difference of \$280,000 (3.5%) separated the UV facility present worth cost for Manufacturers B and C (base bid, no wipers) for the common header design approach. The risk associated with the non-validated status of the reactor proposed by Manufacturer B was concluded to be low because of the validation history of similar reactors, ability to add additional rows should the validated performance fall short of the design requirements, and existing field experience with identical components in operating UV facilities. The risk associated with the UV

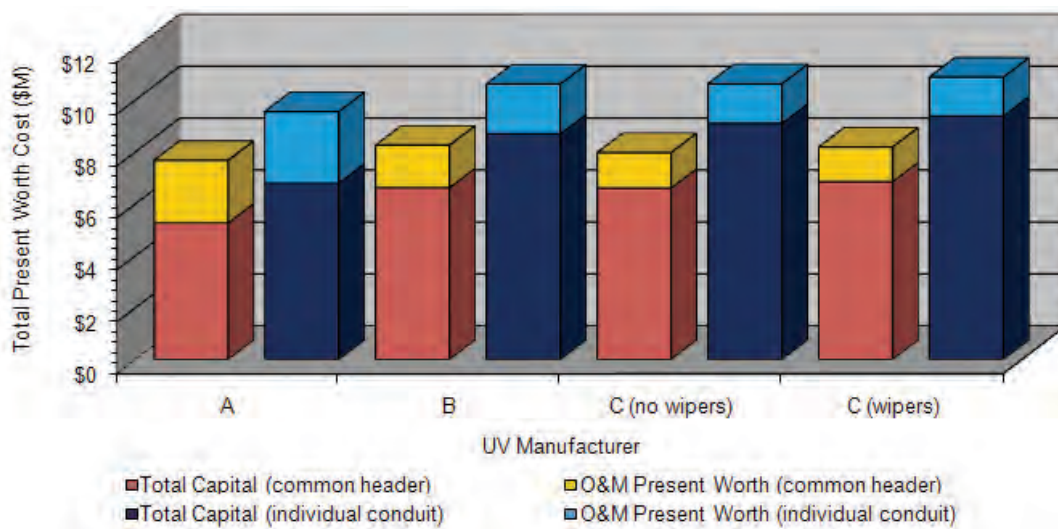

Figure 6: UV Facility Total Present Worth Costs (Million \$USD)

reactor proposed by Manufacturer C was concluded to be much greater, not only because UV reactors employing similar lamp and ballast technologies had not been validated, but also these components did not have an established track record to determine their reliability. Although the common header based design had some margin of safety, any added disinfection capacity would have to be acquired through the installation of additional reactors should the validation results not support the UV system sizing.

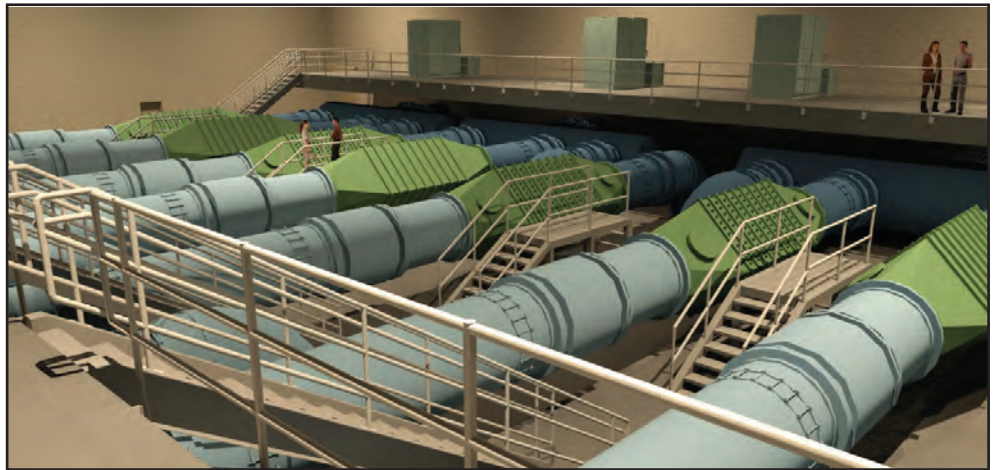

Figure 1: Early Artist Rendition of the Bull Run UV facility (final design will only have 5 UV reactors)

UV Manufacturer B, ITT Wedeco, was selected by the PWB evaluation committee to supply the UV reactors for the Bull Run UV facility (**Figure 7**). The detailed design of the Bull Run UV disinfection facility is currently underway and incorporates common influent and effluent headers shared by all conduits. The UV reactor, model K143 12/11(13), consisting of 11 banks of 12 lamps (expandable to 13 banks) will be validated in the spring of 2011 at the Portland, OR UV Validation Facility.

REFERENCES

WRF (2010). Development of a UV Disinfection Knowledge Base #3117. Water Research Foundation, Denver, Colorado.

UV %Transmission Analyzers

HF scientific has a history of over thirty years manufacturing quality water testing equipment and is poised to be the leader in drinking water and wastewater UV disinfection monitoring. Our UV %Transmission Analyzers use the latest in microprocessor technology to ensure accuracy and affordability in the drinking water and wastewater disinfection industry.



**UVT-15
Transportable**

- Rugged case
- Self-contained
- Simple calibration



**AccUView
Online**

- Continuous ultrasonic cleaning
- Auto ranging 0 - 100%T
- Low maintenance



**AccUView Wastewater
Online**

- Continuous ultrasonic cleaning
- Auto ranging 0 - 100%T
- Bellows pump

Visit our web site for more information:

www.hfscientific.com



Ft. Myers, FL toll free: 888-203-7248 • fax: (239) 332-7643 • hfinfo@watts.com

